

REVISIONS				
ECN	REV.	DESCRIPTION	DATE	APPROVED
13616	1	ADDED UL CERTIFICATIONS	6/9/2023	TTS

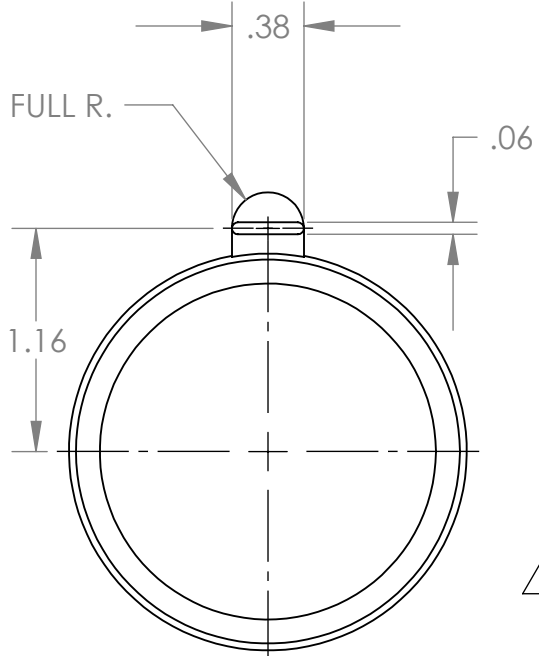
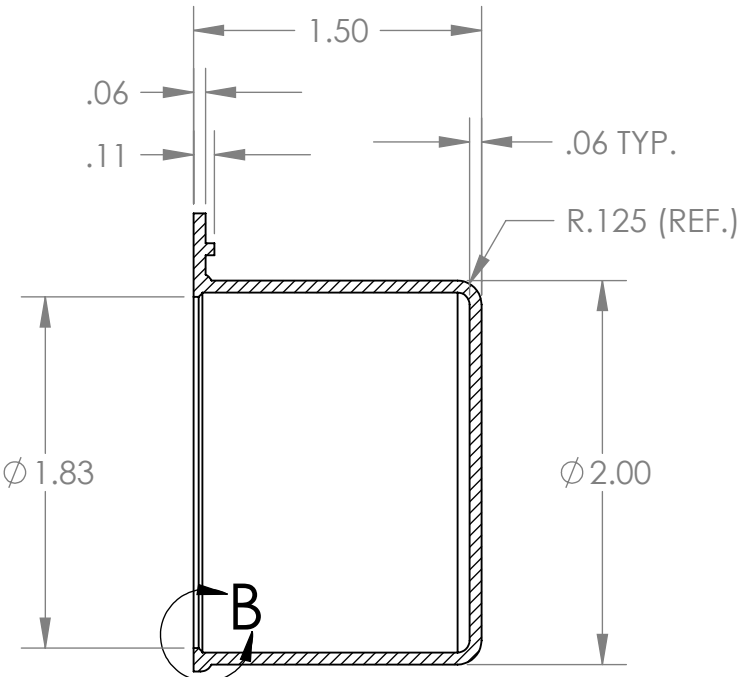
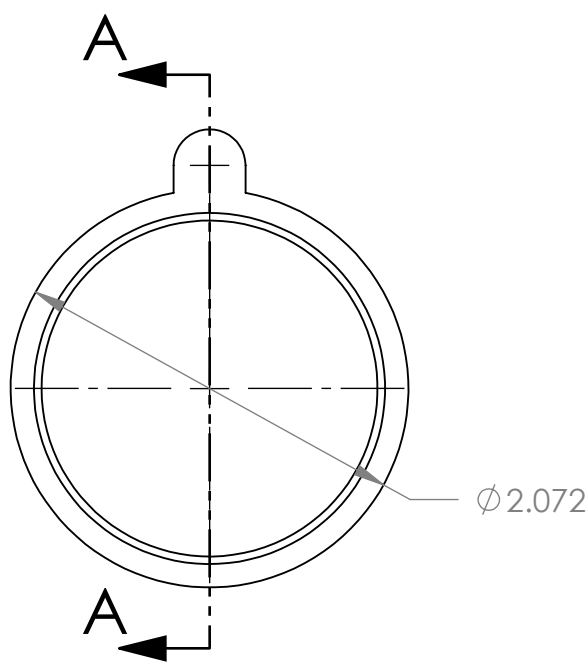

THIS MATERIAL HAS BEEN EVALUATED IN ACCORDANCE WITH THE REQUIREMENTS FOR GASKETS IN:

THE ELEVENTH EDITION OF UL 50, STANDARD FOR ENCLOSURES FOR ELECTRICAL EQUIPMENT

THE FIRST EDITION OF UL 50E (CONTINUOUS COMPRESSION ONLY), STANDARD FOR SAFETY FOR ENCLOSURES FOR ELECTRICAL EQUIPMENT, ENVIRONMENTAL CONSIDERATIONS

THE FINAL APPLICATION SHOULD BE REVIEWED TO DETERMINE WHETHER THE TEST RESULTS INCLUDED HEREIN ARE COMPATIBLE FOR THE FINAL USE DEVICE AND WHETHER OPERATION, LEAKAGE OR OTHER MECHANICAL TESTS ARE REQUIRED

THIS PRODUCT HAS BEEN EVALUATED TO BI-NATIONAL STANDARD CAN/CSA - C22.2 NO 236-M90, UL 1995

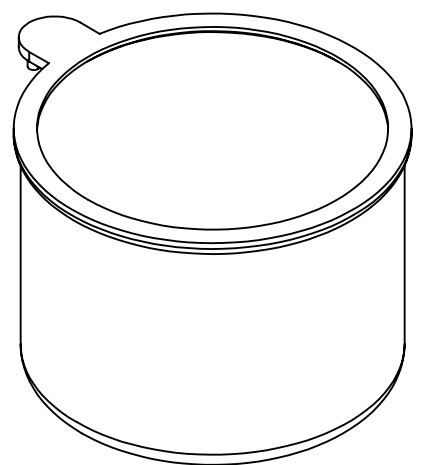
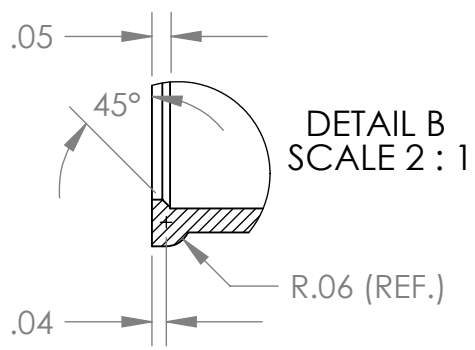

VOLUME: .76in³

UNLESS OTHERWISE SPECIFIED:	NAME	DATE
DIMENSIONS ARE IN INCHES TOLERANCES:	DRAWN MAD	12/04/08
PER RMA CLASS A3 "COMMERCIAL"	CHECKED	
	ENG APPR.	
	MFG APPR.	
INTERPRET GEOMETRIC TOLERANCING PER:	PROPRIETARY AND CONFIDENTIAL	
MATERIAL F65024	THE INFORMATION CONTAINED IN THIS DRAWING IS THE SOLE PROPERTY OF LAVELLE INDUSTRIES, INC. ANY REPRODUCTION IN PART OR AS A WHOLE WITHOUT THE WRITTEN PERMISSION OF LAVELLE INDUSTRIES, INC. IS PROHIBITED.	
DO NOT SCALE DRAWING		

Lavelle Industries, Inc.		
TITLE: CAPACITOR BOOT		
SIZE B	DWG. NO. M8150	REV 1
SCALE: 1:1	WEIGHT:	SHEET 1 OF 1